

Ambiguities and Deviations in Qualitative Circuit Analysis

Mark H. Lee, Jonathan Bell and George M. Coghill

Centre for Intelligent Systems
Department of Computer Science
University of Wales, Aberystwyth, UK
mhl@aber.ac.uk

Abstract

Qualitative electrical circuit models have now been developed by the QR community to the extent that they can be found in commercial software products. Our own work, including this paper, deals with steady-state models applied to design analysis tasks in automotive electrical systems.

Our previous method using three valued resistance networks has been very successful in certain applications, particularly those that address the effects of structural circuit changes. More recently we have introduced a many-valued model that allows the effects of value changes to be analysed.

In this paper we describe two innovations: a method for the resolution of flow directions and a new treatment of deviations. Both of these are based on a many-valued resistance model with an order-of-magnitude relation. The first technique generalises previous methods and the second offers a new functionality for such models.

Introduction

The reason why it is important to develop and explore qualitative circuit modelling techniques lies in their potential value for future engineering tools. Such tools will have access to both conventional quantitative models and higher level (qualitative) abstractions which allow meta-level reasoning to be performed, thus giving greater understanding of circuit behaviour and better analysis and design capabilities. This need has been felt in the ECAD community where sophisticated packages produce voluminous numeric output but are unable to interpret the meaning of the data in terms of basic circuit events. It is this meaning, in terms of qualitative properties and states, that QR techniques have the potential to capture, and so can enhance rather than replace existing circuit analysis tools.

Previous papers have discussed this relationship between qualitative modelling of electrical circuits and the more conventional, numerical electrical circuit modelling methods (Lee 1999b). We believe qualitative circuit models should be used to capture the essence of a circuit configuration, and can then be used to reason about the meaning of that configuration. We intend “meaning” to stand for an interpretation that ex-

plains the relation between the configuration and desired behaviour of the circuit. Hence, an oscillator and an amplifier may have nearly identical configurations but small key differences (in structure or parameters) will lead the reasoning process to discern their different roles.

We believe this is an important area for development in support of the next generation of circuit simulation and engineering tools. Various authors have addressed qualitative circuit issues through different tasks such as diagnosis, design and analysis. Software tools are now being developed for such applications and embody qualitative models in contrast to the numerical equation solvers used in most electrical simulation packages.

This paper first outlines the goal of work on QR circuit tools by indicating the major desirable features. Next we examine how far these goals have been reached and identify some remaining problems. Then we describe a method for the resolution of flow directions in many-valued resistance models using order-of-magnitude relations. Finally, we present a new approach to deviations based on the models described. These contributions are summarised in the conclusion.

Desirable Features of a QR Circuit Tool

A considerable range of engineering tools is in existence, not least those provided for electrical circuit design and analysis. Experience with these and other ECAD tools has shown the power of numerical equation solving systems for electrical simulation. However, purely quantitative models do not capture all the intent of the designer and there are various limitations that QR methods have the potential to alleviate.

Vividness. It is noticeable that engineers often use very simple models in order to obtain insight into a system, especially in the early stages of analysis. It seems that abstract, minimal models allow rapid reasoning with simple conceptual structures, and are quite sufficient for the higher, less detailed levels of analysis. It is important, therefore, that any software support tools contain models that match or readily map into forms appropriate for human use. Complex models or very large quantities of data will not find

favour with engineers and will entail increased errors and other difficulties.

Integration of Quantitative and Qualitative. As reported previously (Lee 1999b), the QR community has apparently been unaware of the efforts of ECAD research engineers to build an intermediate grain-size model of electrical circuits. The goal is to reconcile the detailed numeric data produced by analog simulators with the notions of state, behaviour and function as used by engineers. It is clear that the simple, intuitive concepts used by engineers are both powerful and qualitative in form, but their integration is a long standing problem. Attempts have been made to combine the configuration and state information generated by gate-level simulators with conventional circuit analysis tools, but these have tended to become a form of approximate numerical analysis. This hits major problems with serious loss of accuracy and difficult algebraic methods.

Generality. Due to the unconstrained scope of the electrical design space it is important that QR methods, like the existing numerical systems, are able to cover all possible topologies of circuit configuration. Most electrical circuits can be represented as directed or undirected graphs, depending on whether current flow is significant or not, respectively. Thus, a great many topological forms may be encountered but they are usually classified into a few basic categories, according to their difficulty of analysis. The simplest circuits are series/parallel (SP) reducible, i.e. those that can be reduced into a single equivalent value by repeated application of standard series parallel reduction rules, (Arnborg *et al.* 1991). Non SP reducible circuits may contain star/delta configurations that need special transforms and some circuit edges might form balanced bridges. These can be difficult to solve because they may require a full numerical solution. Any useful QR method must be general enough to cover all these cases.

Granularity. The level of granularity chosen for a QR circuit model will often be a compromise between conflicting needs. The quantity space must be sufficiently finely partitioned to distinguish significant differences in levels of activity but no more so than is absolutely necessary to satisfy the application (there is no advantage in a qualitative model that approaches numerical accuracy). This topic relates to the issue of integration and we see that fine detail qualitative models should not be needed for circuit work — when very fine detail is necessary an integrated system should request an analysis from an existing quantitative system.

Modelling structural and non-structural changes.

Much of diagnosis and analysis is concerned with the effects caused by circuit elements changing in some way. Circuits can change only by structural alterations (the removal or creation of new connections) or by changes in values of component parameters. Being

able to analyse the effects of both sorts of changes is an important requirement for a comprehensive circuit tool.

Current Progress in QR Circuit Modelling

In this paper we refer to steady-state circuit analysis; dynamic systems are not covered here. The main theoretical work in this area has been in constraint propagation (Struss *et al.*, 1997), tree decomposition methods (Mauss and Neumann, 1996) and graph traversal algorithms (Lee 1999a). Successful commercial applications are seen in the packages RAZ'R (Occ'm Software, 1998) and AutoSteve (Price *et al.*, 1995) for diagnosis and FMEA respectively. Our work originated in the development of qualitative models that underpins the AutoSteve development.

Vividness. Our work on three valued resistance for the CIRQ formulation (Lee 1999a) can be seen as the most minimal qualitative model possible for circuit representation. This system was designed to address the specific requirements of FMEA tasks for electrical systems. Electrical FMEA in the automotive sector essentially concern the effects of faults of only two classes: open-circuit faults and short-circuit faults. These can be treated as structural faults and, in most electrical FMEA, are sufficient for the analysis of most fault classes. These minimal models maintain structural isomorphism with the real system and proved very effective for FMEA.

Granularity. In order to expand the scope of CIRQ to deal with parameter changes, we investigated an order-of-magnitude quantity space for resistance. Our system, called MCIRQ (Lee 2000), allows an n valued quantity space to be set up by the engineer and then circuit paths can be reported in terms of different current levels corresponding to the various qualitative impedance levels. This is an advance over CIRQ in that value changes can now be modelled and their consequences determined.

Generality. Although CIRQ can process star/delta configurations, all bridges have to be reported as ambiguous because comparisons are impossible with only one significant value of load resistance. With MCIRQ many of the unbalanced bridge cases can be resolved when the arms of the bridge contain different qualitative values.

Modelling structural and non-structural changes.

As mentioned above, MCIRQ can represent different resistance values and this allows non-structural changes to be modelled. This is a significant improvement over our earlier CIRQ which could effectively only model changes in circuit structure.

Integration of Quantitative and Qualitative.

We believe effective integration can be achieved through *parallel operation* of conventional numeric circuit analysis with QR simulation, thus producing

dual output that can be cross-correlated to maximum effect. Such a system could label each wire, node or component with both actual voltage/current and qualitative labels that signal important application specific conditions. This seems to offer considerable potential for a coherent modelling environment on which to build future engineering reasoning tools.

Outstanding Problems

There still remain a few problems that need resolution in order to fully satisfy the requirements necessary for a general QR circuit tool. We use MCIRQ as a framework for enhancements. MCIRQ is based on an n -valued order-of-magnitude quantity space (OM) for resistance, e.g. for $n = 5$: $Q(r) = [0, lo, med, hi, \infty]$ where $0 \ll lo \ll med \ll hi \ll \infty$. Notice that only 3 values ($n - 2$) are available to differentiate qualitative current levels. We introduce a function that determines the ratio of OM quantities: $R_{OM}(r_1, r_2)$. This gives the difference between two values, in steps on the OM scale, and can be used to compare quantities. For example, $R_{OM}(hi, lo) = 2$, $R_{OM}(hi, med) = 1$, and $R_{OM}(med, hi) = -1$.

We now consider three problem issues:

Directions of flow. This has been a problem area because qualitative circuit values are usually *local* but flow directions are determined by *global* considerations. CIRQ estimated the flow direction between any two nodes by comparing their values using a potential divider rule:

$$\text{potential of } u \text{ (from positive)} = \frac{f(u)}{f(u) + r(u)}$$

where $f(u)$ and $r(u)$ are the forward and reverse resistance values to positive and negative supply for node u respectively. This was a useful heuristic but not a general solution and the multiple values in MCIRQ makes this method even less general (Lee 2000).

Bridges. We note that balanced bridges can not be solved by *any* qualitative method. For example, if four resistances surrounding a bridge are a , b , c , and d , then balance is achieved if:

$$a/b = c/d$$

If these ratios are unequal then the direction of the inequality gives the direction of flow. However, *without precise quantitative values* the exactly balanced case can not be determined. With a set of similar qualitative values the bridge could be balanced, or have flow in either direction, hence we label such cases “ambiguous”. Nevertheless, if some of the arms of the bridge have *distinguishably different* values then the unbalanced case may be determined. MCIRQ finds such cases where CIRQ can not, (because MCIRQ has $n - 2$ different values while CIRQ has only one). The basis of this method is to evaluate:

$$R_{OM}(a, b) = R_{OM}(c, d)$$

Unfortunately, the labelling scheme described in (Lee 2000) is not general for all cases. Although all the examples given are correct there exist certain cases where a lower valued bridge edge can disturb the values at the ends. Figure 1 shows a simple example of a possibly balanced bridge. If the bridge edge, X ,

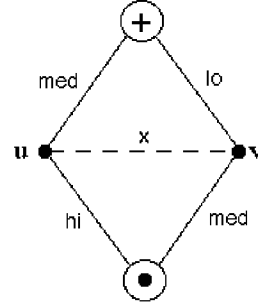

Figure 1: A balanced bridge

is ignored then the f/r values for the nodes u and v can be compared as potential dividers. These values, med/hi and lo/med both have the same OM ratios ($R_{OM} = -1$) and so the edge must be labelled “ambiguous”. It is clear that the value of the resistance of the edge X can have *no* effect on the balance condition. However, a low value for X will alter the labels — e.g. if $X = med$ then the f/r values become med/med and lo/med , and the direction of flow through the bridge is (erroneously) determined.

Deviations. CIRQ can handle only structural changes, i.e. changes in circuit connectivity. (Hotz *et al.* 1997) claim that this limitation, of dealing with only structural changes and not component variation, also applies to most other recent qualitative circuit modelling methods. MCIRQ allows component resistance changes and this permits the effects of value changes to be detected and analysed, but only with order-of-magnitude differences. We wish to address the more general case of parameter variation.

The flow direction and bridge problems are closely related and are solved in the next section, while the subsequent section gives a new deviation technique.

Flow Resolution in non SP Circuits

The method used in MCIRQ, as reported in (Lee 2000), is to reduce iteratively all SP branches of a circuit to their equivalent (qualitative) values. This will either reduce the whole circuit to a single resistance, in which case the current may be determined directly, or it will result in a non SP network containing possible bridges. In the former case the total current flow in the circuit, I , (i.e. at the main terminals) will be inversely proportional to the circuit’s equivalent resistance value, R' . We are using an OM quantity space for resistance and a single fixed voltage source and so we can define current in terms of the flow that would be produced by a given resistance:

r	0	lo	med	hi	∞
i	∞	hi	med	lo	0

Table 1: For a given voltage, resistance and current have an inverse relation: $i = inv[r]$

Thus, a current may be given as a value from $inv[r]$ or simply in terms of resistance — as the current that is appropriate for resistance r .

When the current for R' has been determined, the value is then reflected back into the SP branches to give the activity levels in all edges.

In the case that a non SP network remains after SP reduction, this much smaller network must be resolved to determine the flow in each branch before these are reflected back to the original edges.

We now replace the labelling system used in MCIRQ for dealing with non SP circuits with a new two stage process. We first find the flow direction of the unambiguous edges using a graph-theoretic procedure related to **Kirchhoff's second law**, and then we exploit **Thevenin's theorem** to explore the electrical conditions of the remaining potential bridge edges.

In CIRQ we used some graph-theoretic methods to remove any dead-end branches and to compress electrically identical nodes into supernodes. We now introduce similar processes for MCIRQ. Using a spanning tree we find a set of *fundamental circuits* of a non SP system in order to locate the edges that have unambiguous flow. This also eliminates any dead branches. The steps involved are as follows:

1. For the final circuit produced from SP reduction, K , generate a spanning tree T rooted at the positive supply node. During this process create a co-tree CT (containing those edges missing from the spanning tree). Note that an artificial edge between the two power supply nodes is included in the co-tree.
2. Take each edge in turn from the co-tree, add to the spanning tree and find the cyclic path that is produced. These *fundamental circuits* are saved and form the basis of the circuit space of K . Note that (a) any dead-end branches have now been eliminated and (b) just one fundamental circuit will have a path between the supply nodes.
3. From the set of fundamental circuits generate all combinations of circuit paths using the ring-sum operator \oplus . The ring-sum of two graphs contains all the nodes from both and the edges which are in either graph but not both. Only circuit paths involving both supply terminal nodes are of interest, so one of the fundamental circuits must be present in all combinations — this halves the number of combinations to be generated.
4. For each generated path, beginning at the positive supply node, perform a traversal to the negative node. During the traversal, the edges between the

supply nodes are assigned directions of flow (using the convention that flow is from positive to negative) and the path resistances are computed. Any circuits that contain closed cycles or disconnected sections are ignored.

5. The edge directions from each circuit path are entered into a **route matrix**. Each edge will end up labelled either consistently with one direction of flow, inconsistently (i.e. ambiguous) or unlabelled (dead branch).

The fundamental circuits represent the loops given by Kirchhoff's voltage law and define the circuit basis. An example is shown in figure 2. In this case the circuit basis contains five fundamental circuits and this gives rise to 31 possible combinations of circuit routes, of which 16 were tested (i.e those containing both supply nodes). 12 valid circuit paths were found, shown in

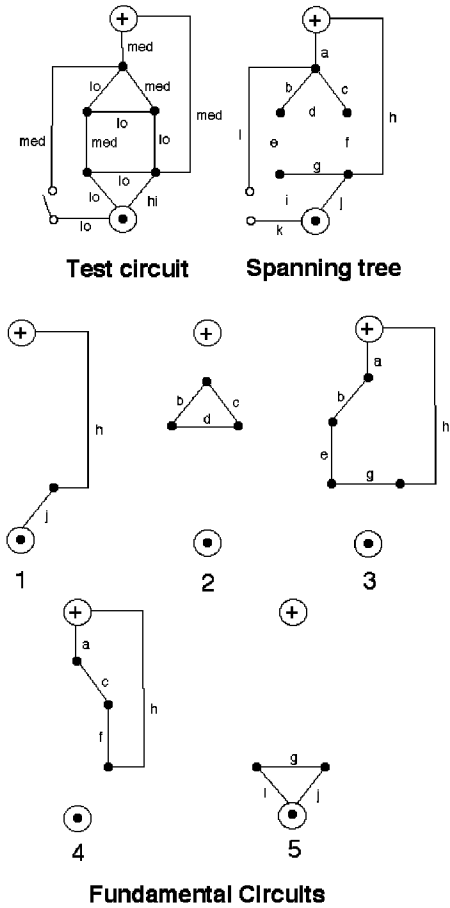

Figure 2: An example circuit, its spanning tree and resulting circuit space

figure 3, and these gave unambiguous flow directions in 6 of the 10 edges in the original circuit. Notice that the dead-end branches, k and l , are eliminated from the fundamental circuits. The route matrix is shown in table 2. In relation to figure 2, a right arrow indicates

Path Number	Circuit Basis	Flow directions (A = ambiguous)											Path Resistance R	Rank	
		a	b	c	d	e	f	g	h	i	j	k			l
1	1								→		→			hi,med	7
2	$1\oplus 3$	→	→			→		→			→			hi,2med,2lo	10
3	$1\oplus 4$	→		→			→				→			hi,2med,lo	9
4	$1\oplus 5$							←	→	→				med,2lo	1
5	$1\oplus 2\oplus 3$	→		→	←	→		→			→			hi,3med,2lo	11
6	$1\oplus 3\oplus 5$	→	→			→				→				2med,2lo	3
7	$1\oplus 2\oplus 4$	→	→		→		→				→			hi,med,3lo	8
8	$1\oplus 4\oplus 5$	→		→			→	←		→				2med,3lo	4
9	$1\oplus 2\oplus 3\oplus 5$	→		→	←	→				→				3med,2lo	5
10	$1\oplus 2\oplus 4\oplus 5$	→	→		→		→	←		→				med,5lo	2
11	$1\oplus 3\oplus 4\oplus 5$		→	←		→	←		→	→				3med,3lo	6
12	$1\oplus 2\oplus 3\oplus 4\oplus 5$				←	→	←		→	→				2med,3lo	4
Resultant flow		→	→	A	A	→	A	A	→	→	→	0	0		

Table 2: Route matrix for figure 3.

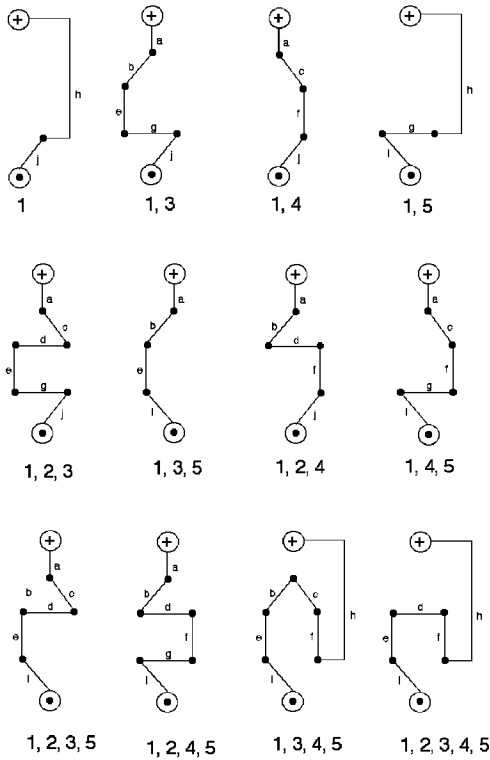

Figure 3: Generated paths give directions of flow

flow down or to the right and a left arrow indicates flow up or to the left. The symbol, A , indicates an ambiguous edge and 0 indicates a dead edge (no flow). The ranking is in order of minimum path resistance.

The second stage is to examine all the remaining edges labelled “ambiguous” making use of a qualitative version of **Thevenin’s theorem**. Thevenin’s theorem states that any linear two-terminal network containing various voltage sources can be replaced by a single resistance, R_{th} , in series with a single voltage source, V_{th} .

(The value of V_{th} is given by the open-circuit voltage experienced at the terminals and R_{th} can be found from $R_{th} = V_{th}/I_{short-circuit}$.)

This means that an edge can be *removed* when determining its end potentials as *its resistance value can have no effect on the direction of flow*. If an order-of-magnitude difference between the end nodes is in evidence then the flow direction can be determined, otherwise the edge must remain labeled “ambiguous”.

For each ambiguous edge in the route matrix

1. Remove the edge from the circuit (or set its value to ∞) and then generate forward and reverse resistance labels (f/r) for all circuit nodes.
2. The labelling process is based on that given in (Lee 2000) but is modified to deliver increased information. Instead of recording the minimum resistance to the supply terminals, a full list of the number of resistances of each OM value on the path are given for f and r .
3. The two edge nodes are compared using a potential divider rule, on the basis of decreasing OM values. If there exists a clear order-of-magnitude difference in the potentials then the direction of flow is assigned accordingly, otherwise the edge remains “ambiguous”. It is possible to grade the degree of ambiguity on the basis of the qualitative results; this allows “likely” flow directions to be assigned with associated confidence levels.

An example of this stage is illustrated in figure 4. Here edge d is being examined and the f/r values at each end are $med, lo/med, lo$ and $med, lo/3lo$. This is an imbalance as the second r is nearer to the negative terminal by an order-of-magnitude and flow can be assigned towards this node. Notice that if the highest value were the same in all four entries then the next lower value could be used for comparison. However, as there would not then be an order-of-magnitude difference the flow could only be indicated tentatively.

For example, with f/r values of $med/med, 4lo$ and $med, lo/med, 3lo$ the equal medium values support the balanced case, but next comparing the lo values, the f value has increased in one direction while the r value has reduced. This allows us to label the edge “ambiguous” but also assign a “likely” direction of flow.

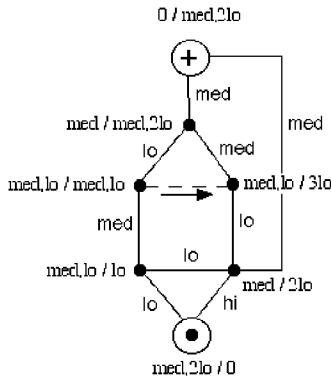

Figure 4: An example of node analysis

Deviations and Sensitivity as a Diagnosis Tool

Using the above method, we can determine the effects of changes by the technique used before in (Lee 1999a). Hence, we perform an analysis on a given circuit, save the results, execute desired changes to component values or circuit structure, perform a second analysis, and then compare the two result sets to identify those values that have altered as a consequence of the circuit component changes. This is a useful analysis process appropriate for design work, particularly FMEA. Our CIRQ system can handle only structural changes, but MCIRQ can detect the effects of resistance changes because it can represent more than one load resistance type.

Thus, analysis is the process of determining the currents in the network from the resistance values of the components. However, in diagnosis we often wish to perform the reverse process, i.e. given a circuit current has changed, which of the components are possible candidates for the cause of the change? We note that the main system variable in our method is current flow and so we will refer to current (rather than voltage) change throughout. We define the concept of change as a deviation from normal.

It is now necessary to define deviations in terms of our electrical quantity space. We do not use the obvious scheme of declaring a deviation w.r.t. a value i_x as being a change of order i_{x-1} because OM changes are too extreme for most applications, and, in any case, these can be simulated with the existing difference analysis method just described. We assume a deviation is larger than a small OM variation on a variable but not so large that it enters the next value in the OM space,

in other words: $i_{x-1} < \delta i_x < i_{x+1}$, (for example, an application might allow δi_x to be between 50% to 500% of i_x). This means that a deviation in a flow value can not be caused by any component of *lower* value. We shall see that higher valued components are also unable to be responsible for a deviation.

The problem then becomes: given a two-terminal section of a network supplied by a nominal current of i_x which has been noticed to change by an amount δi_x , produce a list of all circuit components (edges) that could account for the change. We use Θ to indicate the disturbed value, i.e. $\Theta i_x = i_x \pm \delta i_x$.

This means if the supply current i_x to a section of a network experiences a deviation the candidate components are all those that (a) have a resistance value of $inv[i_x]$ and (b) are the maximum values on series branches or the minimum values on parallel branches. An example is shown in figure 5. Here a prior analysis

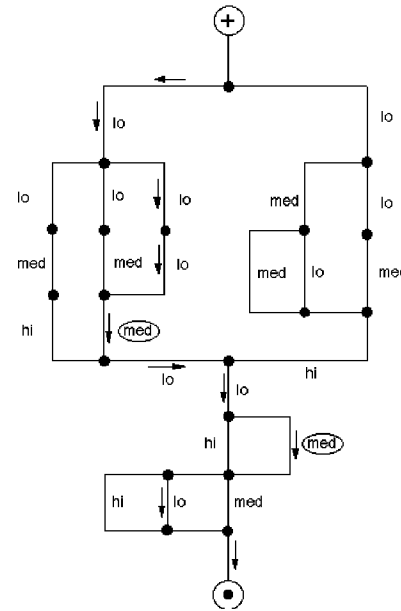

Figure 5: Locating deviation candidates

has determined that the current supplying the circuit is $inv[med]$, i.e. a level appropriate to the circuit’s equivalent resistance being med (actually, $2med, 6lo$). Consequently all med values are suspects: lower values can be eliminated as they could not vary enough to be detectable as a med deviation, and higher values can only affect the network if they are on the primary path(s), which is impossible by definition. Because of the max and min rules for series and parallel branches we see that of the 8 med values in the network in figure 5 only 2 are candidates (circled): the others are either bypassed by lower parallel branches or are dominated by higher valued series components. Thus the deviation candidates lie on the primary path(s) through the circuit.

In the case of a non SP network the candidates are

again selected from the main flow path(s); an example is given in figure 6. This case illustrates that when a parallel branch has more than one minimal edge then there will be more than one primary flow path to be considered. In the circuit of figure 4 there are 4 *med* valued resistors and all are candidates for the cause of a deviation on the network input current because (a) they are of the same OM as the network resistance and (b) in this case, they are all on primary flow paths. If such a circuit is the result of SP reduction then the candidate edges are expanded to locate all candidates in the SP branches, using the above rules.

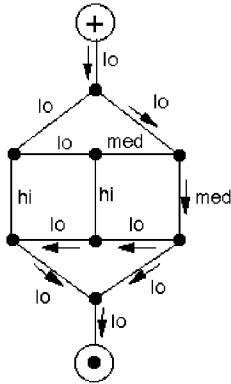

Figure 6: Locating candidates in non SP circuits

This method can be applied to any section of a network, providing a two-terminal structure is selected. If a two-terminal partition is not easily available then the boundary of the desired portion can be expanded or contracted until a suitable partition is found. The method does not order the candidates but only reports their location. Further external information (such as reliability data) could be used to order and select external probe points so that further candidates may be eliminated.

Discussion

Although the example of diagnosis has been used, it is also possible to employ the deviation technique described here for design analysis. Indeed, the method has close affinities with the idea of **sensitivity analysis** in simulation and design work. After a design or prediction study has been completed it is common practice to generate further results by applying small perturbations to the key variables. The aim of this is to find which variables (if any) have strong influences on the design, and discover how sensitive the design is to those variables.

Regarding the size of the circuit space, for a circuit of E edges and n nodes there are $E - n + 1 = S$ fundamental circuits in the circuit space. This gives $2^S - 1$ combinations of the fundamental circuits to be examined. However, not all of these are relevant — only those containing both supply terminals are to be considered — this reduces the number of combinations to 2^{S-1} . This

exponential growth rate of the algorithm may seem prohibitive but we must remember that it is *not applied to the full network* but only to the reduced circuit K . In our experience of automotive circuits, original circuits of thousands of nodes and edges typically reduce to small K s of the size illustrated by the examples of this paper. As an extreme case, we built an artificially complex test K and this gave $E = 33, n = 23$, producing 1024 paths to be examined. Also, once these paths have been entered in the route matrix the following stages are all based on rapid look-up retrieval.

The route matrix is very useful for constructing the primary flow paths in non SP circuits. For example, in the case of the circuit in figure 2, the matrix shows path number 4 has the lowest path resistance. The components on this path with the same OM level are added to the candidate list (i.e. component h). Then the next lowest resistance path is considered (number 10), and this adds component a to the list. Next, path number 6 adds component e and finally path number 8 contributes component c .

We observe that this gives us a possible alternative method to using Thevenin's theorem for flow direction determination. In fact, the route matrix may provide sufficient data to label flow directions in all branches. Given that we only have to resolve the ambiguous cases, that is edges c, d, f , and g in table 2. A method we are investigating is to adopt the flow directions given by the minimal resistance path first and then sequentially add in labels from each of the next ranking paths provided they do not conflict with any prior labelling. The lowest resistance path is path number 4 with a value of $med, 2lo$, and this gives a direction for edge g . The next lowest path is path 10 and this adds directions for edges d and f . The next ranking path makes no contribution but the following one, path number 8, gives the final label, for the edge c .

Related work

Interesting work on the use of qualitative deviations for diagnosis has been carried out by (Struss *et al.*, 1997), particularly in the domain of hydro-mechanical systems. This has shown how deviations can capture key behavioural characteristics that can be matched against models giving significant gains in diagnosis with very limited observations. Like our methods, these can also be applied to analysis and design application areas.

Most related work concerned with electrical systems has dealt with the analysis or effects of structural changes in circuits and we find very little reporting on non-structural or parameter changes. The work of (Hotz *et al.*, 1997) is an exception and describes the differences between existing (structural) methods, which are based on constraints, connectivity propagation and series-parallel-star tree reduction, and the requirements for analysing non-structural changes. They argue that deviations from a norm are the key factor during diagnosis and develop a method using qualitative deviations. A series of circuit rules are used to propagate

current and voltage values and a form of series-parallel-star tree reduction (Mauss and Neumann, 1996) is used to reduce the resistive nets. The main problems with this method are that it relies on topology dependent rules, it cannot handle bridges, and it is not general for all circuit topologies. Like (Mauss and Neumann, 1996) this method can carry out some numerical reduction in parallel but it suffers from a loss of user affinity (re: vividness) due to the complications involved in processing decomposition trees. Recent work by these authors (Milde *et al.*, 1999), continues with applications of these methods but does not overcome the above problems. For example, the notation is very cumbersome, with different qualitative representations for voltage, current and resistance. While we agree with their motivation, we believe our formalism offers various advantages.

Conclusions

We have presented several new methods for improving and extending certain qualitative modelling tools for reasoning in the electrical circuit domain. Following a description of several remaining problems we have given solutions and illustrated their results. First we have shown how bridges can be located and treated consistently so that they are resolved if at all possible and labelled as ambiguous otherwise. We also give a solution to the flow direction problem and offer two alternatives, a qualitative version of **Thevenin's theorem** or a constructive approach based on the fundamental circuits from **Kirchhoff's theory**. In either case we see the considerable utility of decomposing a non-SP circuit into its full set of flow path routes. Another contribution is a treatment of deviations using the notion of deviations lying *within* the range(s) set by an OM quantity space. Thus these deviations are more like perturbations rather than transitions. This offers different features and advantages compared with deviations modelled as value changes and has clear promise for diagnosis and other applications. There remains more to be done in this area and this can be further developed for applications in both diagnosis and design.

In all of these methods the benefits have been gained because of the use of an OM quantity space. We view the OM space as a way of classifying the parameters of a given circuit into different levels corresponding to distinctive semantic meanings for the engineering user. Thus a circuit might have an equivalent resistance of *hi* and, when connected to the supply, we would expect a current in the region of *inv[hi]* to be drawn. As the circuit changes, in either structure or component values, so the active paths, of *hi*, *med* or any number of values in the quantity space, will shift to reflect how the power, signal, leakage, or other levels, have changed as a consequence. Our prototype Java implementation displays each OM level as a different colour — thus highlighting the qualitatively different branches and aiding their interpretation. We believe this scenario illustrates the advantages of QR methods and their complementarity with more traditional numeric circuit techniques.

This supports our claim that qualitative and quantitative tools should be combined using parallel operation to gain their mutual benefits in an integrated environment for engineering applications.

References

- Arnborg S., Courcelle B., Proskurowski A. and Seese D., An Algebraic Theory of Graph Reduction, in *Graph Grammars and Their Application to Computer Science*, H. Ehrig, H.-J. Kreowski and G. Rozenberg (Eds.), Lecture notes in Computer Science, 532, pp70-83, 1991.
- Hotz L., Milde H., Moller R. and Neumann B., Resistive Networks Revisited: Exploitation of Network Structure and Qualitative Reasoning about Deviations is the Key, In *Proc. 8th Int. Workshop on Principles of Diagnosis, (DX'97)*, France, 1997, pp123-27.
- Lee M.H., Qualitative Circuit Models in Failure Analysis Reasoning, *Artificial Intelligence*, vol 111, pp239-276, 1999a.
- Lee M.H., Qualitative Modelling of Linear Networks in ECAD Applications, in *Proc. 13th Int. Workshop on Qualitative Reasoning, (QR'99)*, Loch Awe, Scotland, pp146-52, 1999b.
- Lee M.H., Qualitative Modelling of Linear Networks in Engineering Applications, in *Proc. ECAI2000, 14th European Conf. on Artificial Intelligence*, Berlin, August 19th - 25th, 2000, pp161-5.
- Mauss J. and Neumann B., Qualitative Reasoning about Electrical Circuits using Series- Parallel-Star Trees, in *Proc. 10th Int. Workshop on Qualitative Reasoning in Physical Systems (QR'96)*, pp147-153, 1996.
- Milde H., Hotz L., Kahl J. and Wessel S., Qualitative Analysis of Electrical Circuits for Computer-based Diagnostic Decision Tree Generation, in *Proc. 13th Int. Workshop on Qualitative Reasoning, (QR'99)*, Loch Awe, Scotland, pp312-18, 1999.
- OCC'M Software GmbH, Gleissentalstr 22, 82041 Deisenhofen, Germany, www.occm.de, 1998.
- Price C.J., Pugh D.R., Wilson M.S. and Snooke N., The Flame system: Automating electrical failure mode and effects analysis (FMEA). in *Reliability and Maintainability Symposium*, Pages 90-95, IEEE 1995.
- Raiman, O., Order-of-magnitude reasoning, *Artificial Intelligence*, 51, pp11-38, 1991.
- Struss P., Sachenbacher M. and Dummert F., Diagnosing a Dynamic System with (almost) no Observations, in *Proc. 11th Int. Workshop on Qualitative Reasoning (QR'97)*, pp193-201, Cortona, 1997.